



TOTALLY DIFFERENT.



Item No. _____

C007

Whipped Cream Dispenser

Features

Garnish all your favorite beverages and desserts with freshly made whipping cream or create your own mousse desserts with the same equipment. Simply mix the ingredients together, and pour into the whipping dispenser. Press the button to serve, with no chemical additives or propellants.

Refrigerated Hopper

Two removable tanks nest inside each other in the hopper: 6.3 qt. (6.0 liter) and 9.5 qt. (9.0 liter). To use the larger tank, simply remove the smaller one; the smaller tank may be used alone, or inside the larger one. Refrigerated to maintain safe product temperatures below 41°F (5°C). Electronic temperature control is adjustable for various product requirements. Hopper temperature is displayed on electronic control.

Whipping Action

Refrigerated liquid cream is pumped through a stainless steel chamber, forcing the cream through multiple paths, incorporating air and whipping into a light and fluffy topping or dessert.

Air Pump

Select the lowest number on the adjustment knob for lower overrun, and adjust to a higher number if a lighter texture is desired. Compact pump, located above the hopper area, easily disassembles for cleaning with no tools.

Dispensing

Convenient push-button can be used for two modes of operation: manual, or timed. For manual operation, just press and hold until desired quantity is dispensed. For timed operation, pre-set the dispensing time in the electronic control for similar portions every serving.

Drip Tray

Clear drip tray and stainless steel holder may be removed as needed.

C007

Rockton, Illinois 61072
800-255-0626
Phone 815-624-8333 Fax 815-624-8000
www.taylor-company.com
e-mail: info@taylor-company.com

International Office
Taylor Company S.r.l.
Roma, Italy
Tel: **+39-06-420-12002** Fax: +39-06-420-12034
e-mail: romeoff@taylor-company.com

ISO 9001:2000
Registered Firm

C007 Whipped Cream Dispenser

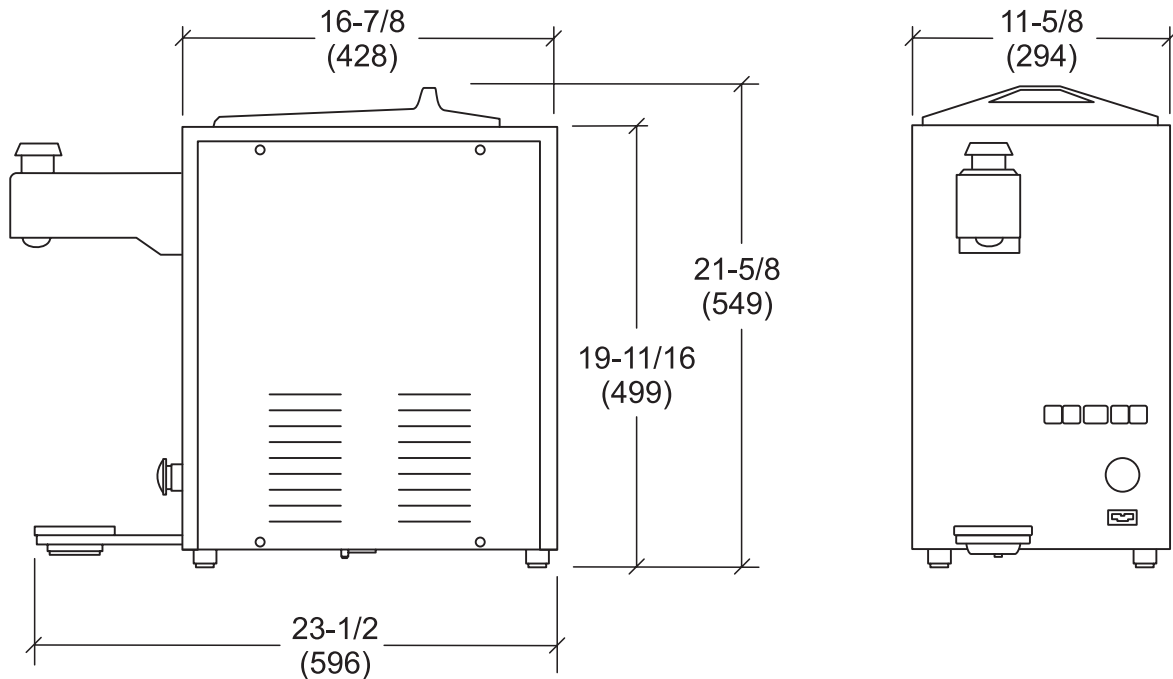

NOTE: FIGURES IN PARENTHESES INDICATE MILLIMETERS.

Weights	lbs.	kgs.
Net	82	37.2
Crated	104	47.2
	cu. ft.	cu. m.
Volume	6.2	0.17

Dimensions	in.	mm.
Width	11-5/8	294
Depth	23-1/2	596
Height	21-5/8	549
Counter Clearance*	1	25

Mounted on standard feet

Electrical	Total Amps	Supplied with NEMA Cord
115/60/1 Air	7.0	5-15P

This unit may be manufactured in other electrical characteristics. Refer to the local Taylor Distributor for availability. (For exact electrical information, always refer to the data label of the unit.)

Bidding Specs

Electrical: Volt _____ Hz _____ ph _____
 Neutral: Yes No Cooling: Air Water NA

Options: _____

Specifications

Electrical

One dedicated electrical connection is recommended. See the Electrical chart for the proper electrical requirements. Manufactured to be cord connected. Consult the international Taylor distributor for cord & receptacle specifications for 50 Hz. equipment.

Refrigeration System

One, 140 BTU/hr compressor. R134a. (BTUs may vary depending on compressor used.)

Pump Motor

One, 1/4 HP.

Air Cooled

Minimum Clearance: 4" (100 mm) around all sides. Minimum air clearances must be met to assure adequate air flow for optimum performance.

Accessories

- Cleaning rod
- O-ring removal tool



Taylor Company,
 A Division of Carrier Commercial Refrigeration, Inc.
 Rockton, Illinois 61072
 815-624-8333 800-255-0626 Fax 815-624-8000
www.taylor-company.com

Printed in U.S.A.