



Item No. \_\_\_\_\_

# C119

## Batch Ice Cream Freezer

### Features

Serve homemade, medium overrun gourmet ice cream, custard, gelato, sorbet, Italian ice and slush. Mix and liquid flavorings may be poured into the convenient fill chute on the door. Fruits, candies and nuts can be folded in as product is being drawn into your container. Manufactured in Italy by Frigomat to ensure European equipment quality and technology to serve gelato or medium overrun frozen desserts.

### Freezing Cylinder

One, 8.5 quart (8.0 liter).

### Electronic Consistency Control

Selection on rotary switch from one to six. Automatically senses product viscosity to control the refrigeration system for perfect ice cream quality, batch after batch.

### Variable Batch Size

Adjust to a lower viscosity setting for smaller pre-charge of mix.



Standard 8



Conforms to ANSI  
UL STD 621  
Certified to CAN  
CSA STD 22.2  
NO 120

Rockton, Illinois 61072  
**800-255-0626**  
Phone 815-624-8333 Fax 815-624-8000  
**www.taylor-company.com**  
e-mail: info@taylor-company.com

International Office  
Taylor Company S.r.l.  
Roma, Italy  
Tel: **+39-06-420-12002** Fax: +39-06-420-12034  
e-mail: romeoff@taylor-company.com

# C119 Batch Ice Cream Freezer

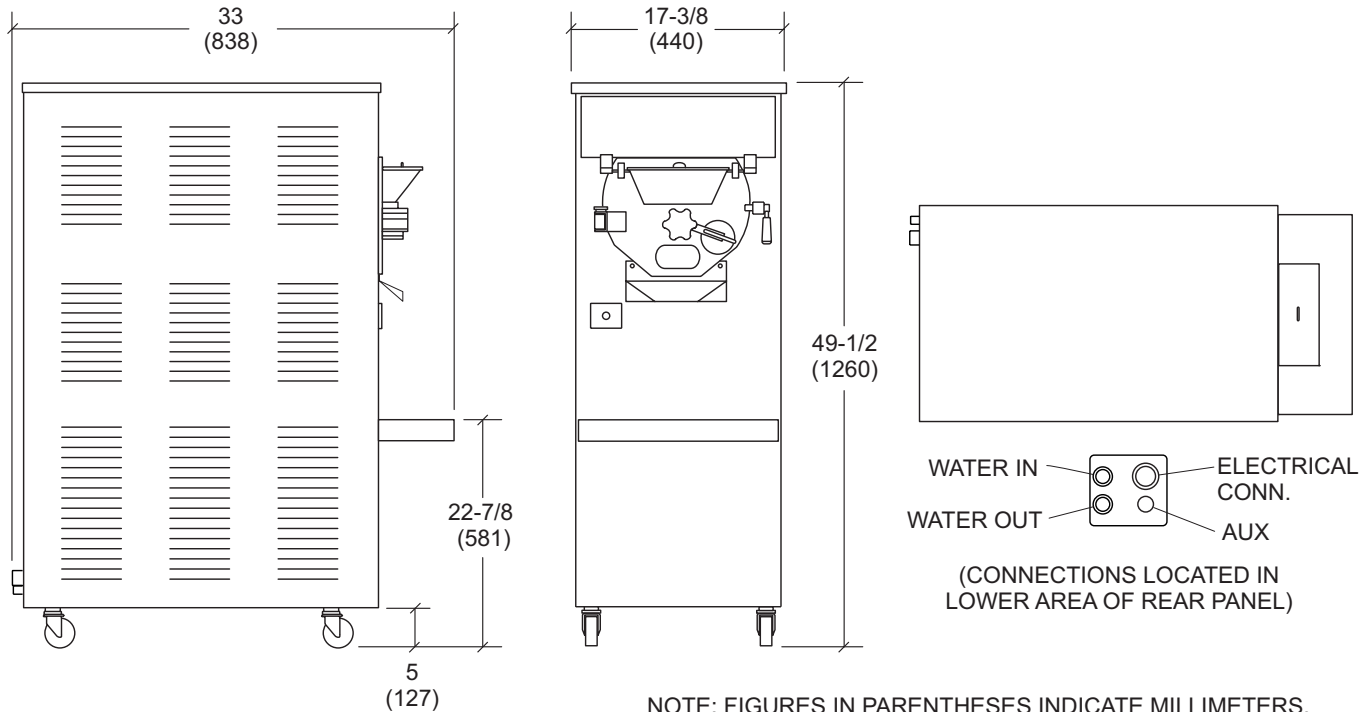

NOTE: FIGURES IN PARENTHESES INDICATE MILLIMETERS.

Weights	lbs.	kgs.
Net	373	169
Crated	478	217
	cu. ft.	cu. m.
Volume	15.9	0.45

Dimensions	in.	mm.
Width	17-3/8	440
Water Cooled Depth	31-7/8	810
Air Cooled Depth	3331-7/8	81038
Height	49-1/2	1260

Counter Clearance: 5" (127 mm) mounted on standard casters

Electrical	Maximum Fuse Size	Minimum Circuit Ampacity	Poles (P) Wires (W)
208-230/60/1 Air	30	24	2P 3W
208-230/60/1 Water	30	24	2P 3W

*This unit may be manufactured in other electrical and cooling characteristics. Refer to the local Taylor Distributor for availability. (For exact electrical information, always refer to the data label of the unit.)*

## Bidding Specs

Electrical: Volt \_\_\_\_\_ Hz \_\_\_\_\_ ph \_\_\_\_\_

Neutral:  Yes  No **Cooling:**  Air  Water  NA

Options: \_\_\_\_\_

## Specifications

### Electrical

One dedicated electrical connection is required. See the Electrical chart for the proper electrical requirements. Manufactured to be permanently connected. Consult your local Taylor distributor for cord & receptacle specifications as local codes allow.

### Beater Motor

One, 2 HP beater motor.

### Refrigeration System

One, approximately 15,500 BTU/hr. R404A. (BTUs may vary depending on compressor used.)

### Air Cooled

Minimum 6" (152 mm) on both sides and 12" (305 mm) at rear. Minimum air clearances must be met to assure adequate air flow for optimum performance..

### Water Cooled

Water inlet and drain connections on back panel 1/2" MPT.

Continuing research results in steady improvements; therefore, these specifications are subject to change without notice.



**Taylor Company,**  
A Division of Carrier Commercial Refrigeration, Inc.  
Rockton, Illinois 61072  
815-624-8333 **800-255-0626** Fax 815-624-8000  
[www.taylor-company.com](http://www.taylor-company.com)

Printed in U.S.A.

058464-ADV 8/09