



RFS-1200 Flake Ice Machine

Model

RFS-1200A

RFS-1200W



Model RFS-1200A
Flake Ice Machine
on B-570 Bin

Standard Features

- Up to 1,339 lbs. (607 kgs) daily flake ice production.
- Now in standard measurements for perfect pairing with 30" ice bins. No adapter needed.
- Service updates facilitate installation and make cleaning easier.
- Energy improvements with RFS models averaging 5% across the line.
- Flake Ice is perfect for food display, salad bars, and cold therapy/healthcare.
- Ice forms around object without bruising and holds objects in place without tipping/spilling.
- High load capacity bearings for enhanced reliability.
- Heavy duty stainless steel cabinet resists corrosion.

COMMERCIAL WARRANTY

<p>ICE MAKER</p> <p>3</p> <p>YEAR</p> <p>PARTS</p>	<p>COMPRESSOR</p> <p>2</p> <p>YEAR</p> <p>LABOR</p>	<p>5</p> <p>YEAR PARTS</p> <p>3 YEAR LABOR</p>
---	--	---

Specifications

Condenser Heat of Rejections (BTU per hour):

Air: 14,000 (average)
Water: 1,500 (average)

Compressor:

Nominal rating: 1.5 HP

Refrigerant:

R-404A

Ice Machine Electric

208-230/60/1 standard.
(230/50/1 also available.)

Minimum circuit ampacity:

15 amps.

Maximum fuse size:

15 amps.

HACR-type circuit breakers can be used in place of fuses.

Operating Limits:

- Ambient Temperature Range: Air- and Water-cooled: 50°-110°F (10°-43°C)
- Water Temperature Range: 37°-90°F (3°-32°C)
- Water Pressure Ice Maker Water In: Min. 14 psi (96.5 kPa) Max. 80 psi (551.1 kPa)
- Condenser Inlet Water In: (water-cooled only) Min 20 psi (137.9 kPa) Max 150 psi (1034.2 kPa) Water Condenser not for sea water applications.

Ice Shape

Flake ice is small hard bits of ice ideally suited for presentation applications.





RFS-1200 Flake Ice Machine

RFS-1200 on B-570 Storage Bin

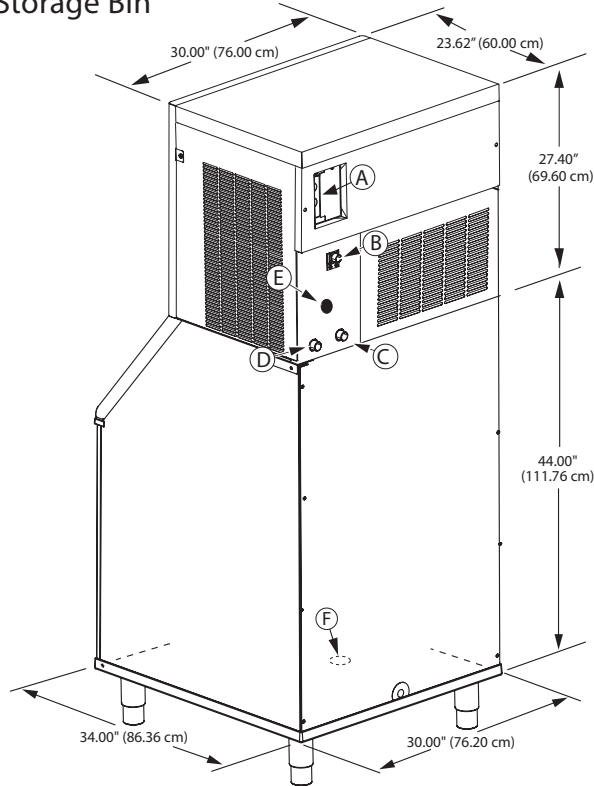

Installation Note -
Minimum installation clearance:
Top/sides: 8" (20.32 cm),
Back: 5" (12.70 cm).

- Ⓐ Electrical Entrance (2) Options
- Air-Cooled Units:**
 - Ⓑ 3/8" F.P.T. Ice Making Water Inlet
 - Ⓒ 1/2" M.P.T. Ice Making Water Drain
- Water-Cooled Unit Option:**
 - Ⓑ 3/8" F.P.T. Condenser Inlet
 - Ⓒ 1/2" M.P.T. Condenser Drain
 - Ⓓ 1/2" M.P.T. Ice Making Water Drain
 - Ⓔ 3/8" F.P.T. Ice Making Water Inlet
 - Ⓕ 3/4" F.P.T. Bin Drain

Space-Saving Design



RFS-1200 on B-570	
Height	77.40" 196.60 cm
Width	30.00" 76.00 cm
Depth	34.00" 86.36 cm
Bin Storage	430 lbs. 195 kgs

Height includes adjustable bin legs
6.00" to 7.00", (15.24 to 17.78 cm)
set at 6.00" (15.24 cm).

Accessories

K-00370 48" B Style Bin Adapter
Adapter not for use with Large Capacity Bins.

Air Flow Overhead View

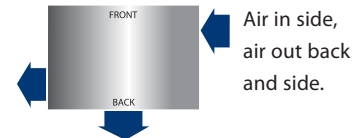

	Model	Ice Shape	Ice Production 24 Hrs.		Power kWh/100 lbs. 90°/70°F 32° Air/21° C Water	Water Usage (100 lbs./45.4 kgs of Ice)	
			70° Air/50°F Water 21° Air/10° C Water	90° Air/70°F Water 32° Air/21° C Water		Potable Water	Condenser Water
Air-Cooled	RFS-1200A	Flake	1,202 lbs.	874 lbs.	5.70	12 gal.	N/A
			545 kgs	396 kgs		45.4 L	N/A
Water-Cooled	RFS-1200W	Flake	1,339 lbs.	1,128 lbs.	3.64	12 gal.	118 gal.
			607 kgs	512 kgs		45.4 L	447 L